

**Rappahannock River Yacht Club
2018 Junior Regatta**

**July 21, 2017
Irvington, Virginia**

**Principle Race Officer: Mosby West – 420/Laser Radial/Sunfish course
Race Officer: Darryl Resio – Opti R/W/B course**

SAILING INSTRUCTIONS

1. RULES

The regatta will be governed by the Racing Rules of Sailing, the rules of the Club 420, Laser Radial, Sunfish, and the International Optimist Dinghy classes, and these Sailing Instructions.

2. ENTRIES

2.1 Eligible boats may enter by completing registration with the Organizing Authority. Eligibility requirements for competitors are:

- a. Applicants for all classes may not turn 19 years of age in 2018.
- c. Optimist class age rules apply.

3. NOTICES TO COMPETITORS

Notices to competitors will be posted on the Official Notice Board located inside the RRYC clubhouse.

4. CHANGES TO THE SAILING INSTRUCTIONS

Any change to the Sailing Instructions for Saturday will be posted on the Official Notice Board within 10 minutes of the conclusion of the Competitors Meeting.

5. SIGNALS MADE ASHORE

5.1 Signals made ashore will be displayed from the back porch of the clubhouse.

5.2 Flag "AP" when displayed with two sound signals means "Racing is postponed. Boats are not to leave the harbor." When lowered with one sound signal, it means "Proceed to the race course. No warning signal will be made in fewer than 60 minutes." This changes RRS Race Signals "AP".

6. SCHEDULE:

Registration/Check-in	0830 – 0915
Competitors Meeting	0930
1 st Warning of Day	1100
Awards Ceremony & Cook-out	ASAP following racing

**No race to start after 1530

Note: Multiple races will be attempted, the goal is 5 races, time and weather permitting.

7. CLASSES & ORDER OF STARTS

	Class	Class Flag
Race Area 1 Rappahannock River	Opti Red, White, Blue (Start together)	Opti Class Flag
Race Area 2 Rappahannock River	420s Laser Radials Sunfish	Purple Flag Blue Flag Sunfish Flag

8. RACING AREAS (SEE ATTACHMENT A)

8.1 The Opti Red, White, and Blue Fleets will race in the Rappahannock River off of Crab Point.

8.2 The Club 420, Laser Radial & Sunfish Fleets will race in the Rappahannock River off of Orchard Point.

9. COURSES

9.1 Course diagrams are presented in Attachment B. As shown in the diagrams all marks are to be rounded to port. The course for each race will be designated by the appropriate letter displayed on the course board on the Race Committee Signal Boat prior to the Warning Signal.

10. MARKS

10.1 Primary marks will be **orange** balls.

11. CHECK-IN

Competitors must check-in with the Race Committee Signal Boat prior to the first race by sailing past the stern of the boat and hailing their sail number until acknowledged.

12. THE START

12.1 All fleets will use the RRS Rule 26 starting system.

12.2 To alert all racers that a sequence is about to begin, the Race Committee will give an Attention Signal consisting of a series of short sounds approximately three (3) minutes before the warning signal for each race.

12.3 The starting line will be between the staff displaying an orange flag on the RC Signal Boat at the starboard end of the line and the course side of an orange mark at the port end.

12.4 Boats whose warning signal has not yet been made shall keep clear of the starting area and of all boats whose warning signal has been made.

12.5 Boats starting more than ten (10) minutes after their starting signal will be scored DNS without a hearing. This changes RRS 63.1, A4, and A5.

13. RECALLS

The Race Committee will attempt to hail the sail number of premature starters. The failure of any boat to hear the hail, the timeliness of the hail, or the position of a boat in the sequence of hails shall not be grounds for granting redress. This changes RRS 29.1, 41, and 62.1.

14. CHANGE OF COURSE AFTER START

To change the next leg of the course, the Race Committee will lay a new mark and remove the original mark as soon as is practicable.

15. THE FINISH

The finish line will be between a staff displaying an orange flag on the RC Finish Boat and the adjacent mark.

16. TIME LIMIT

16.1 A race in which no boat in a fleet finishes within 45 minutes of that fleet's start will be abandoned for that fleet.

16.2 Boats failing to finish within 20 minutes after the first boat in that fleet finishes will be scored DNF. This changes RRS 35.

17. PROTESTS

17.1 RRS 61.1 is changed so that a boat intending to protest another boat must hail its intent to protest and the sail number of the boat being protested to the RC Finish Boat immediately after finishing and be acknowledged by the Race Committee. This notification shall take place before the competitor has spoken with or received input from any coach, support person, or parent.

17.2 Protests shall be in writing and delivered to the Race Committee within 45 minutes of the RC Signal Boat for that course docking at RRYC. Docking time will be posted on the Official Notice Board. Protest forms are available at the Official Notice Board.

17.3 A notice of protests and requests for redress and a tentative schedule of hearings will be posted on the Official Notice Board within 20 minutes after the expiration of Protest Time. This posting constitutes the notification of Race Committee or Protest Committee protests required by RRS 61.1(b).

17.4 Notice of redress hearings shall serve as notice to all boats, whether listed as parties to the hearing or not, that they may attend the hearing.

17.5 It is the responsibility of each boat to check the Official Notice Board to see if it has been cited in a protest or if a redress request involves it or its interests. Failure of a boat to appear at any hearing will be considered grounds to proceed with the hearing under RRS 63.3.

18. SCORING

18.1 The Low Point Scoring System of Appendix A will be used except that there will be one throw-out if four (4) or more races are completed.

18.2 Optimist dinghies will be scored as an overall fleet and also scored separately as Red, White, and Blue fleets.

18.3 One race must be completed to constitute a regatta.

19. COACH AND SUPPORT BOATS

19.1 All coach and team support boats must remain well clear of the racing area from the Preparatory Signal until all boats have finished. Communicating in any way with competitors who are racing will be considered "outside help" under RRS 41 and may result in disqualification of that competitor and/or support personnel either for that race or for the entire regatta. This restriction does not apply to coaches and/or support personnel rendering immediate assistance to any competitor in an emergency situation. Safety is paramount at all times.

20. SAFETY

20.1 A Coast Guard approved Personal Flotation Device shall be worn and properly fastened at all times while launching and sailing, except for very brief periods to change clothing. A whistle permanently attached to the PFD is recommended.

20.2 A boat retiring from a race shall notify a Race Committee vessel before leaving the racing area or, if that is not possible, a regatta official immediately upon arriving ashore.

20.3 When launching and hauling out, all competitors shall follow check-in and check-out procedures as described at the Competitor's Meeting.

21. PRIZES

Trophies will be awarded to the overall top three (3) finishers in each class.

22. DISCLAIMER OF LIABILITY

Competitors participate in the regatta entirely at their own risk. See rule 4, Decision to Race. The organizing authority will not accept any liability for material damage or personal injury or death sustained in conjunction with or prior to, during, or after the regatta.

Attachment A: Racing Areas

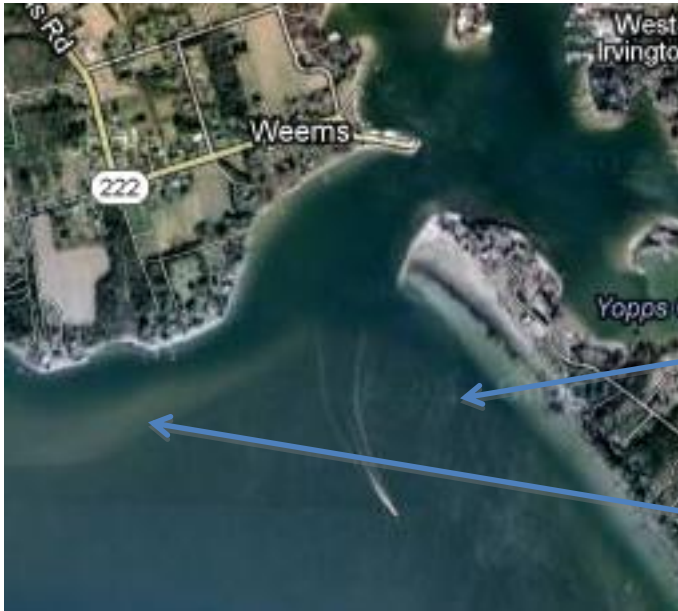

Red, White,
Blue Area

420, Laser
Radial,
Sunfish
Area

Attachment B: Courses

T-Triangle

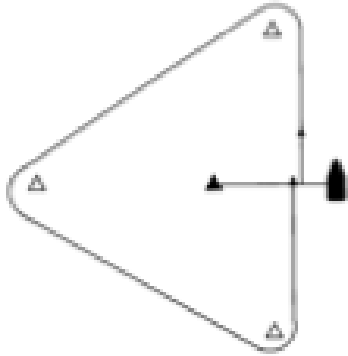

W-Windward Leeward 1 Lap

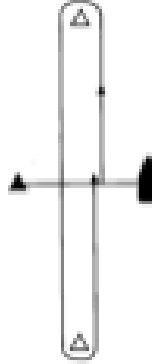

O-Olympic

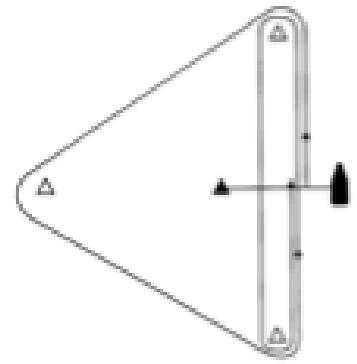

W2- Windward Leeward 2 Laps

